

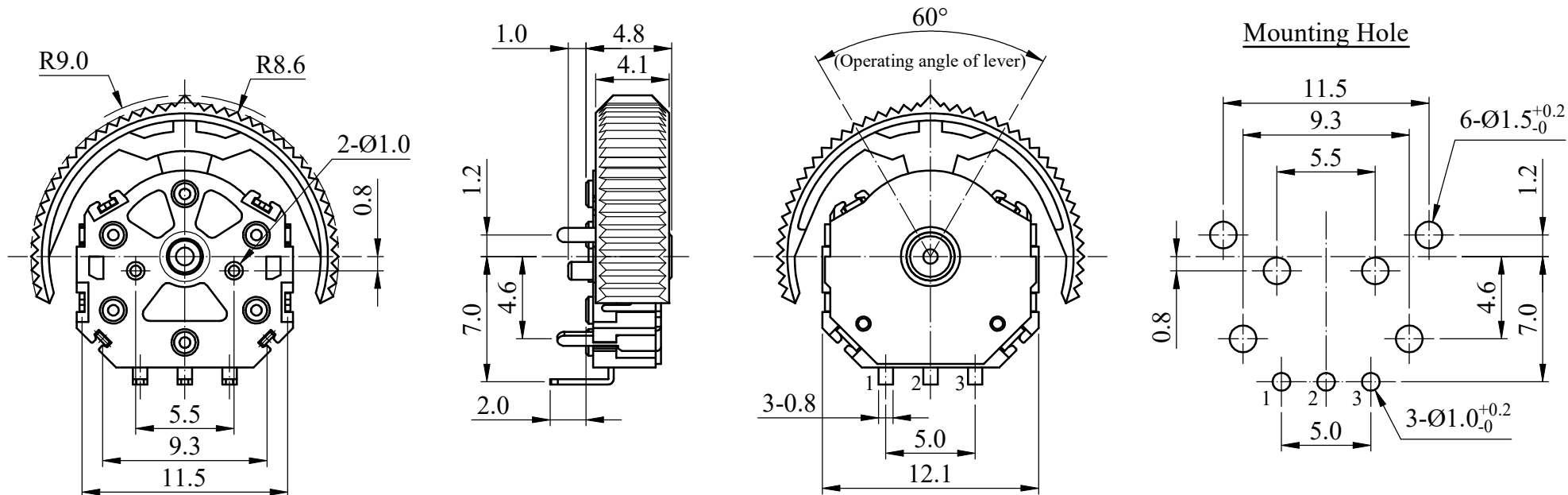

ISO 9001 國際品質認證  
ISO 9001 CERTIFICATE

松暉電機工業股份有限公司  
SONG HUEI ELECTRIC CO., LTD.  
佛山市松暉電機科技有限公司  
FOSHAN SONG HUEI ELECTRIC CO., LTD.

一般事項 General	
使用溫度範圍 Operating temperature	-10 °C ~ +70 °C
儲存溫度 Storage temperature range	-25 °C ~ +85 °C
手工焊接 Manual soldering	300 °C max 3 sec
電氣特性 Electrical Characteristics	
總阻值 (R) Total resistance	10 KΩ
總阻值容許誤差 Total resistance tolerance	± 20 %
阻值線性 Resistance taper	B
電氣有效角度 Angle of Effective electrical	80° ± 5°
定格電力 Rated power (W)	0.03 W
額定電壓 Rated voltage (V)	$E = \sqrt{P * R}$ E: Rated voltage 額定電壓 (V) P: Power rating 額定電力 (W) R: Nominal total resistance 公稱全阻抗值 (Ω) 當額定電壓超過最高使用電壓的時候，最高使用電壓即為額定電壓。 When the rated voltage exceeds the maximum operating voltage, the maximum operating voltage shall be the rated voltage.
最高使用電壓 Max operating voltage	AC 50 V ; DC 10 V
絕緣阻抗 Insulation resistance	More than 50 MΩ at DC 250 V 1 minute
耐電壓 Withstand voltage	1 minute at AC 250 V
機械特性 Mechanical Characteristics	
作動力 Operating force	20 ~ 100 gf.cm
止檔強度 Stopper strength	0.5 Kgf.cm max
推拔強度 Push-pull strength of shaft	4 Kgf max
運轉角度 Operating angle of lever	60° ± 10°
工作壽命 Operating life	100,000 cycles



CIRCUIT

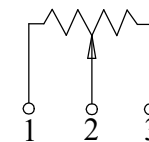

Non notation tolerance	
< 10	±0.3
10 ~ 100	±0.5
> 100	±0.8

**S**® SONG HUEI ELECTRIC CO., LTD.  
FOSHAN SONG HUEI ELECTRIC CO., LTD.

MODEL: J1201/0506

Approval

2024-03-13  
黃珈琳

Checked

廠長  
2024-03-13  
鄧記穩

Drawn

R&D  
2024-03-13  
何鴻根

UNIT

mm

SCALE

3:1

VERSION

1.0

DATE

2024.03.13

DRAWING NO.

SS-156

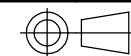

ISSUE

SUBJECT

NAME

DATE

RECORD