



ISO 9001 國際品質認證
ISO 9001 CERTIFICATE

松暉電機工業股份有限公司
SONG HUEI ELECTRIC CO., LTD.
佛山市松暉電機科技有限公司
FOSHAN SONG HUEI ELECTRIC CO., LTD.

一般事項 General	
使用溫度範圍 Operating temperature	-10 °C ~ +70 °C
手工焊接 Manual soldering	300 °C max 3 sec
電氣特性 Electrical Characteristics	
總阻值 (R) Total resistance	10KΩ
總阻值容許誤差 Total resistance tolerance	± 20%
阻值線性 Resistance taper	B Taper
摺動雜音 Sliding noise	Less than 300 mV
電氣有效角度 Angle of Effective electrical	333 ° ± 5 °
定格電力 Rated power (W)	0.1 W
額定電壓 Rated voltage (V)	$E = \sqrt{P * R}$ E: Rated voltage 額定電壓 (V) P: Power rating 額定電力 (W) R: Nominal total resistance 公稱全阻抗值 (Ω) 當額定電壓超過最高使用電壓的時候，最高使用電壓即為額定電壓。 When the rated voltage exceeds the maximum operating voltage, the maximum operating voltage shall be the rated voltage.
线性误差 Linearity tolerance	± 5%
絕緣阻抗 Insulation resistance	More than 100 MΩ at DC 250 V
耐電壓 Withstand voltage	1 minute at AC 250 V
機械特性 Mechanical Characteristics	
全回轉角度 Total rotational angle	360 °
全回扭力 Rotational torque	5~30 gf.cm
推拔强度 Push-pull strength of shaft	1 Kgf max
回轉壽命 Rotational life	100,000 cycles

2.5mm depth of slot

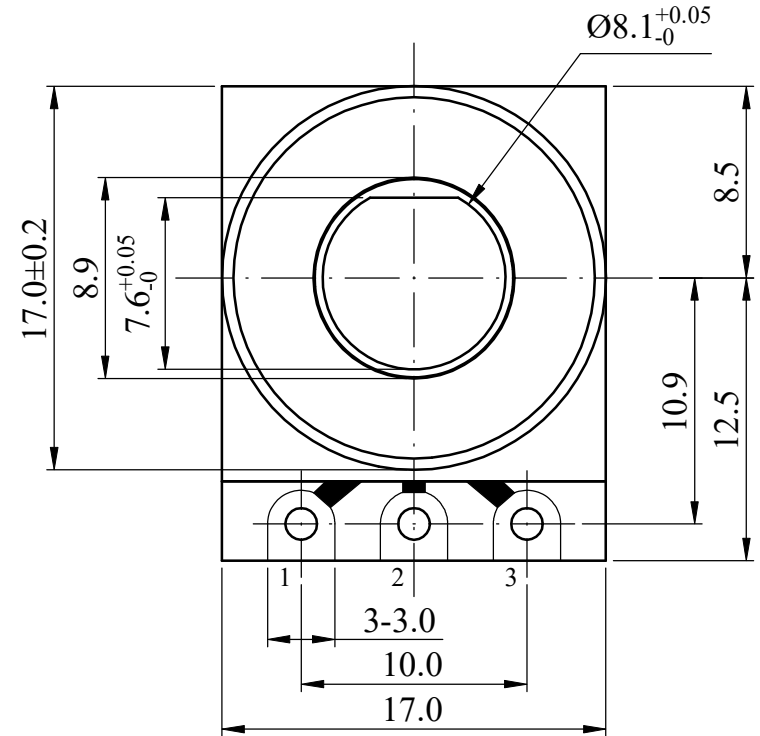
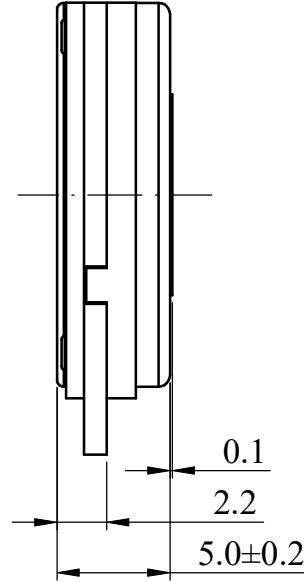
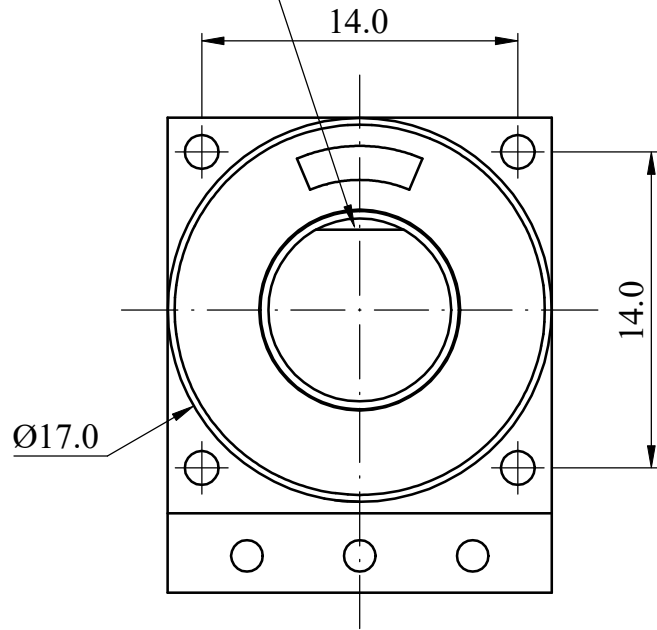

CIRCUIT

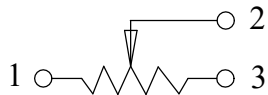

Non notation tolerance	
< 10	±0.3
10 ~ 100	±0.5
> 100	±0.8



SONG HUEI ELECTRIC CO., LTD.
FOSHAN SONG HUEI ELECTRIC CO., LTD.

MODEL: RD1809/0506

Approval



Checked



Drawn



UNIT

mm

SCALE

3:1

VERSION

1.0

DATE

2024.03.11

DRAWING NO.

SS-155

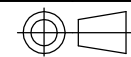

ISSUE

SUBJECT

NAME

DATE

RECORD