

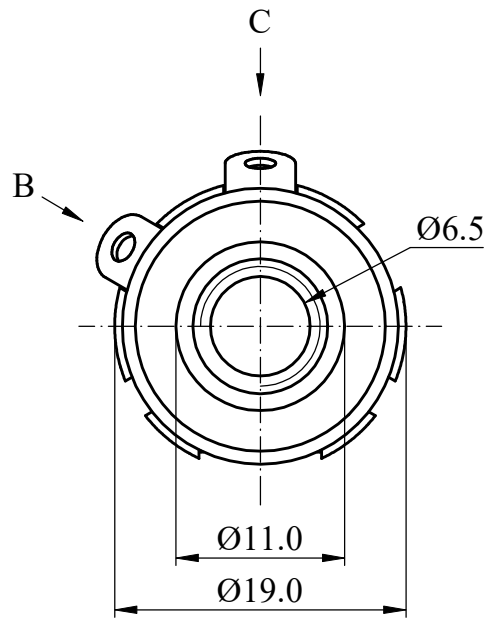

ISO 9001 國際品質認證
ISO 9001 CERTIFICATE

松暉電機工業股份有限公司
SONG HUEI ELECTRIC CO., LTD.
佛山市松暉電機科技有限公司
FOSHAN SONG HUEI ELECTRIC CO., LTD.

| 一般事項 General | |
|---------------------------------|-----------------------------|
| 使用溫度範圍 Operating temperature | -10 °C ~ +70 °C |
| 手工焊接 Manual soldering | 300 °C max 3 sec |
| 電氣特性 Electrical Characteristics | |
| 接觸電阻 Contact resistance | Less than 100 mΩ |
| 額定值 Rating | DC30 V 0.1 A |
| 絕緣阻抗 Insulation resistance | More than 100 MΩ at DC500 V |
| 耐電壓 Withstand voltage | 1 minute at AC 500 V |
| 機械特性 Mechanical Characteristics | |
| 插拔力 Plug and pull force | 30~200gf.cm |
| 插座的壽命 Life of jacks | 5,000 cycles |

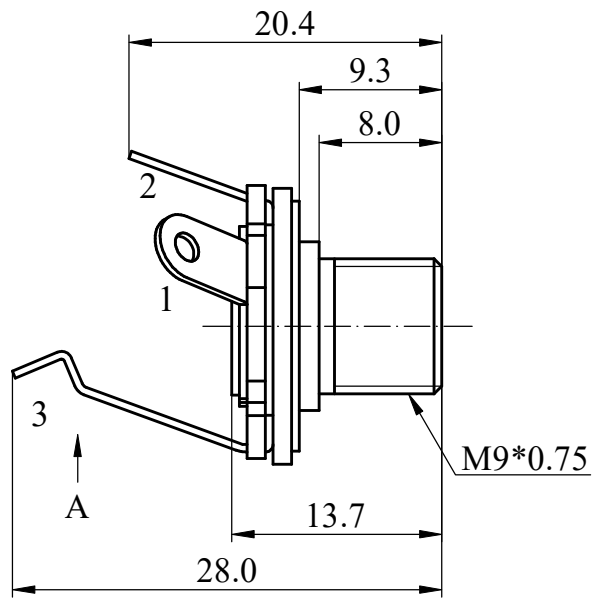

SCHEMATIC

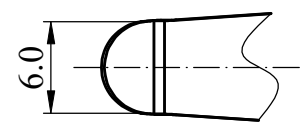
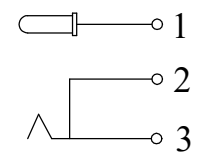

A VIEW

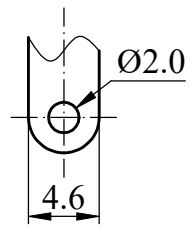

B VIEW

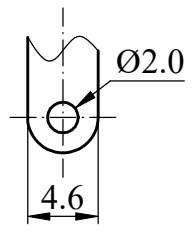

C VIEW

| Non notation tolerance | |
|------------------------|------|
| < 10 | ±0.3 |
| 10 ~ 100 | ±0.5 |
| > 100 | ±0.8 |

S® SONG HUEI ELECTRIC CO., LTD.
FOSHAN SONG HUEI ELECTRIC CO., LTD.

MODEL: SJ-19-3P/0485

| | | |
|----------|---------|-------|
| Approval | Checked | Drawn |
| | | |

| | | | |
|-------------|--------|-------|------------|
| UNIT | mm | SCALE | 2:1 |
| VERSION | 1.0 | DATE | 2024.07.01 |
| DRAWING NO. | SS-165 | | |

| | | | |
|--------|---------|------|------|
| | | | |
| | | | |
| | | | |
| | | | |
| ISSUE | SUBJECT | NAME | DATE |
| RECORD | | | |