

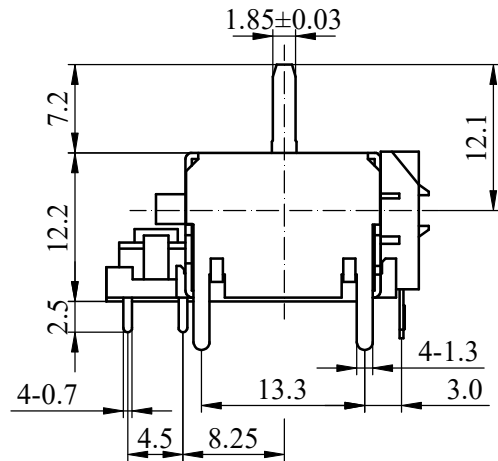

ISO 9001 國際品質認證  
ISO 9001 CERTIFICATE

松暉電機工業股份有限公司  
SONG HUEI ELECTRIC CO., LTD.  
佛山市松暉電機科技有限公司  
FOSHAN SONG HUEI ELECTRIC CO., LTD.

一般事項 General	
使用溫度範圍 Operating temperature	-10 °C ~ +70 °C
儲存溫度 Storage temperature range	-30 °C ~ +80 °C
手工焊接 Manual soldering	260 °C max 3 sec
電氣特性 Electrical Characteristics	
總阻值 (R) Total resistance	<input type="checkbox"/> 5 KΩ <input type="checkbox"/> 10 KΩ <input type="checkbox"/> 100 KΩ
總阻值容許誤差 Total resistance tolerance	<input type="checkbox"/> ± 20% <input type="checkbox"/> ± 10%
阻值線性 Resistance taper	B Taper
電氣有效角度 Angle of Effective electrical	<input type="checkbox"/> 45 ° ± 5 ° <input type="checkbox"/> 55 ° ± 5 °
摺動雜音 Sliding noise	Less than 300 mV
殘留阻值 Residual resistance	Less than 500 Ω
定格電力 Rated power (W)	0.0125 W
額定電壓 Rated voltage (V)	$E = \sqrt{P * R}$ E: Rated voltage 額定電壓 (V) P: Power rating 額定電力 (W) R: Nominal total resistance 公稱全阻抗值 (Ω) 當額定電壓超過最高使用電壓的時候，最高使用電壓即為額定電壓。 When the rated voltage exceeds the maximum operating voltage, the maximum operating voltage shall be the rated voltage.
最高使用電壓 Max. operating voltage	AC 50V or DC 5.0 V
絕緣阻抗 Insulation resistance	More than 100 MΩ at DC 250 V 1 minute
耐電壓 Withstand voltage	1 minute at AC 250 V
機械特性 Mechanical Characteristics	
止強度 Rotational stopper strength	3 Kgf.cm max 3 sec
推拉強度 Push-pull strength	3 Kgf max 3 sec
作動力 Operating force	10 ~ 100 gf.cm
運轉角度 Operating angle of lever	60 ° ± 5 °
工作壽命 Operating life	100,000 cycles
開關特性 Switch Characteristics ( 僅適用於附開關機種 For switch type use only )	
定格電力 Rated power	12 V DC 50 mA
接觸阻抗 Contact resistance	100 mΩ max
開關動作力 Operating force of tact switch	600 ± 200 gf.cm
工作壽命 Operating life	100,000 cycles

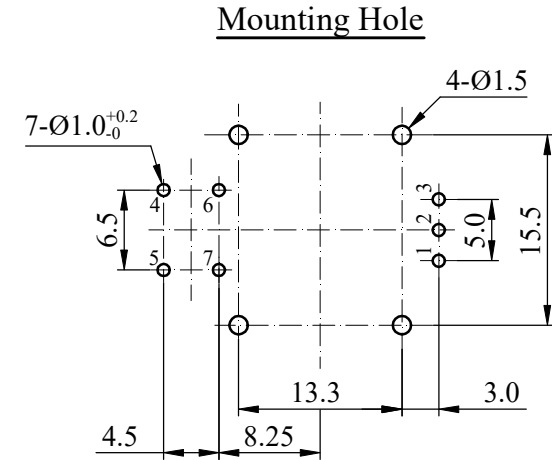
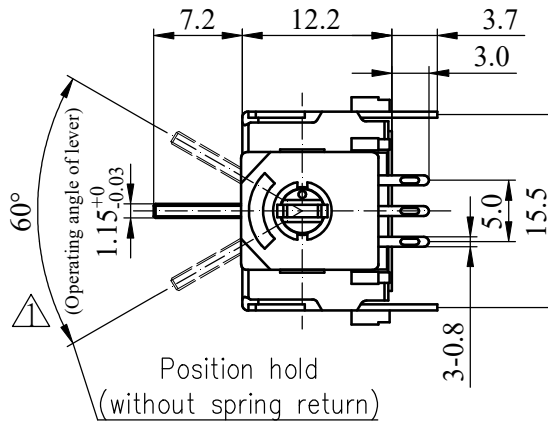
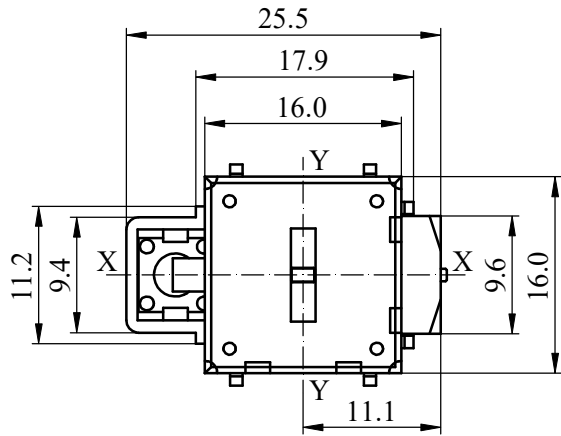

CIRCUIT

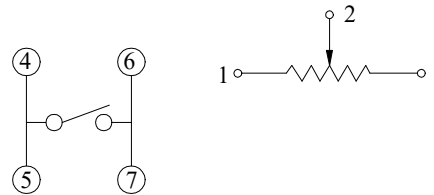

Non notation tolerance	
< 10	±0.3
10 ~ 100	±0.5
> 100	±0.8



SONG HUEI ELECTRIC CO., LTD.  
FOSHAN SONG HUEI ELECTRIC CO., LTD.

MODEL: SJ11YZ/0506

△			
△			
△			
△	修正描述	何鸿根	2023.10.18
ISSUE	SUBJECT	NAME	DATE

Approval  
R&D  
2023-10-18  
藍濬毅

Checked  
廠長  
2023-10-18  
鄧記穩

Drawn  
R&D  
2023-10-18  
何鸿根

UNIT	mm	SCALE	2:1
VERSION	1.1	DATE	2023.07.17

DRAWING NO. SS-139



RECORD