

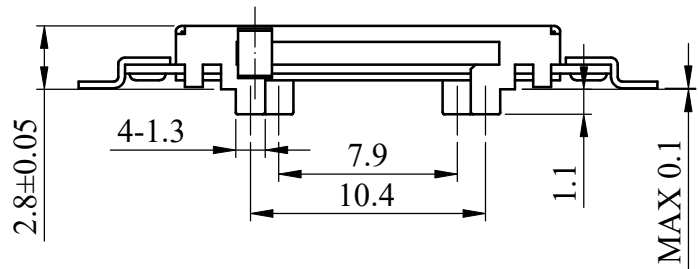

ISO 9001 國際品質認證
ISO 9001 CERTIFICATE

松暉電機工業股份有限公司
SONG HUEI ELECTRIC CO., LTD.
佛山市松暉電機科技有限公司
FOSHAN SONG HUEI ELECTRIC CO., LTD.

一般事項 General	
使用溫度範圍 Operating temperature	-10 °C ~ +70 °C
手工焊接 Manual soldering	300 °C max 3 sec
電氣特性 Electrical Characteristics	
總阻值 (R) Total resistance	10 KΩ
總阻值容許誤差 Total resistance tolerance	± 20 %
阻值線性 Resistance taper	B
摺動雜音 Sliding noise	Less than 100 mV
殘留阻值 Residual resistance	Less than 20 Ω
定格電力 Rated power (W)	0.025 W
額定電壓 Rated voltage (V)	$E = \sqrt{P * R}$ E: Rated voltage 額定電壓 (V) P: Power rating 額定電力 (W) R: Nominal total resistance 公稱全阻抗值 (Ω) 當額定電壓超過最高使用電壓的時候，最高使用電壓即為額定電壓。 When the rated voltage exceeds the maximum operating voltage, the maximum operating voltage shall be the rated voltage.
最高使用電壓 Max operating voltage	AC 100 V; DC 12 V
絕緣阻抗 Insulation resistance	More than 50 MΩ at DC 100 V
耐電壓 Withstand voltage	1 minute at AC 250 V
機械特性 Mechanical Characteristics	
滑動行程 Travel length	10 mm ± 0.5mm
滑動力距 Operating force	10 ~ 100 gf.cm
作動止強度 Stopper strength	1 Kgf.cm max
軸推拉強度 Shaft push-pull strength	1 Kgf max
滑動壽命 Sliding life	10,000 cycles

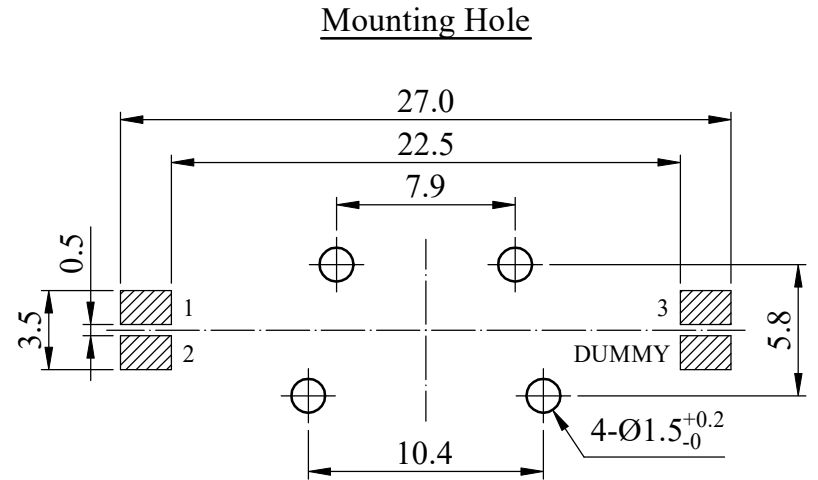
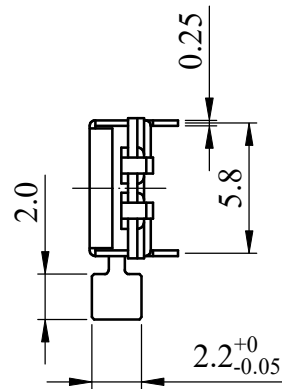
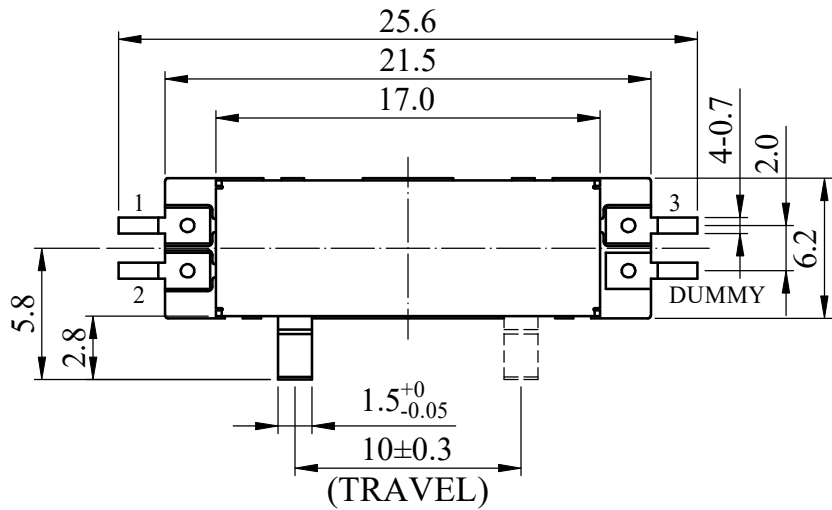

CIRCUIT

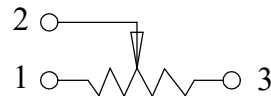

Non notation tolerance	
< 10	±0.3
10 ~ 100	±0.5
> 100	±0.8



SONG HUEI ELECTRIC CO., LTD.
FOSHAN SONG HUEI ELECTRIC CO., LTD.

MODEL: SL1010(2.8C)/0506

△			
△			
△			
△			
ISSUE	SUBJECT	NAME	DATE
RECORD			

Approval

2024-03-13
黄珈琳

Checked

廠長
2024-03-13
鄧記穩

Drawn

R&D
2024-03-13
何鴻根

UNIT	mm	SCALE	3:1
VERSION	1.0	DATE	2024.03.13
DRAWING NO.	SLV-083		